

OD-Mounted Auto-Feed Pipe Beveling Machine

This series machine adopts METABO motor, main applied in the field of power plant pipeline installation, chemical industry, shipbuilding, especially pipeline prefabrication and low clearance on site working, such as maintain thermal power auxiliary equipment, boiler pipe valve.

Features

- OD-Mounted
- Light weight
- Adjustable speed
- Compact design, good rigidity
- Tool feed/back automatically
- Original German METABO motor
- Ingenious centering device, easy for process various of pipe size

METABO Motor

- Model: BE 1100
- 230V -50/60 HZ 1100W 5.3A
- N 2800/Min (rpm)
- Made in Germany

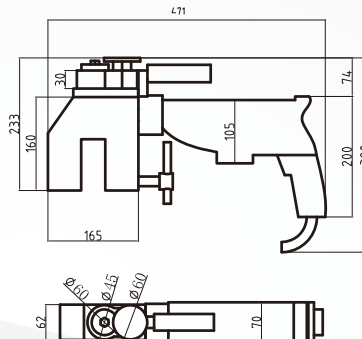
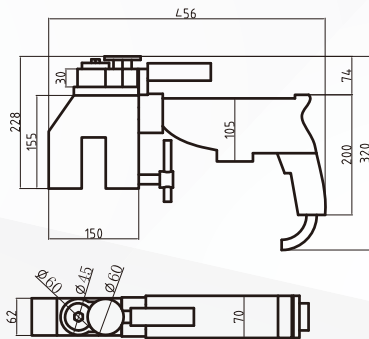

Specification

Model	Working Range	Wall thickness	Clamp Size
	OD mm	mm	OD mm
AF-63C	28-63	≤12	28, 32, 42, 45, 48,51,54, 57, 60, 63.5
AF-76C	42-76		42, 45, 48,51,54, 57, 60, 63.5, 68, 76

* Custom-made clamp size is available